

UNAPPROVED

1

December 7, 2009

A special joint meeting of the City Council and the Parks and Recreation Commission was held on Monday, December 7, 2009, at 6:00 p.m. in Conference Room B in City Hall. Mayor Donker presided.

Councilmen present: Thomas Adams, Maureen Donker, Scott Gaynor, Bruce Johnson, Marty Wazbinski

Councilmen absent: None

Commission members present: Sid Allen, Frank Altimore, Patty Carlson, Paula Jurado, David Kelley, Charles Martin, Marcia Steidemann

Commission members absent: Lois Berthiaume, Kristen Bovid

PARKS AND RECREATION FEE PHILOSOPHY

Public Services Director Karen Murphy presented information for a discussion on various parks and recreation fees.

Being no further business the meeting adjourned at 6:25 p.m.

Selina Tisdale, City Clerk

UNAPPROVED

December 7, 2009

A regular meeting of the City Council was held on Monday, December 7, 2009, at 7:00 p.m. in the Council Chambers of City Hall. Mayor Donker presided. The Pledge of Allegiance to the Flag was recited in unison.

Councilmen present: Thomas Adams, Maureen Donker, Scott Gaynor, Bruce Johnson, Marty Wazbinski

Councilmen absent: None

MINUTES

Approval of the minutes of the November 23, 2009 regular meeting was offered by Councilman Gaynor and seconded by Councilman Adams. (Motion ADOPTED.)

PUBLIC COMMENTS

No public comments were made.

GOLF COURSE FEES

Assistant City Manager Jack Duso presented for second reading and adoption an ordinance to amend Section 21-71 of Division 2 of Article II of Chapter 21 – Golf Course Fees. Gregg Clark, 2779 Beaver Ridge Road, Midland, Vice President of Operations at Sandy Ridge Golf Course, spoke regarding the overall golf industry, local play analysis and the concerns he has with Currie reducing some of its pricing. Ray Senesac, 1401 Harwood Court, spoke regarding volume and pricing at Currie. Frank Altimore, 2209 Norwood and a member of the Parks and Recreation Commission, spoke in support of the new Currie pricing structure. The following ordinance amending golf course fees was then offered by Councilman Johnson and seconded by Councilman Wazbinski:

ORDINANCE NO. 1686

AN ORDINANCE TO AMEND THE CODE OF ORDINANCES OF THE CITY OF MIDLAND, MICHIGAN, BY AMENDING SECTION 21-71 OF DIVISION 2 OF ARTICLE II OF CHAPTER 21 THEREOF.

The City of Midland Ordains:

Section 1. Section 21-71 of Division 2 of Article II of Chapter 21 is amended to read as follows:

Sec. 21-71. Golf Course Fees

The fees for golfing privileges at the Currie Municipal Golf Course are as follows:

Currie East Municipal Golf Course Daily Fees

9-hole rate

Regular weekday	\$11.50 per play
Regular weekend	\$11.50 per play
Senior weekday (7:00 a.m. – 3:00 p.m.)	\$ 8.00 per play
Youth weekday & weekend	\$ 5.00 per play

18-hole rate

Regular weekday	\$15.00 per play
Regular weekend	\$15.00 per play
Senior weekday (7:00 a.m. – 3:00 p.m.)	\$13.00 per play
Youth weekday & weekend	\$ 9.00 per play

Currie West Municipal Golf Course Daily Fees

9-hole rate

Regular weekday	\$15.00 per play
Regular weekend	\$15.00 per play
Senior weekday (7:00 a.m. – 3:00 p.m.)	\$10.00 per play

UNAPPROVED

Youth weekday & weekend 18-hole rate	\$ 8.00 per play
Regular weekday	\$25.00 per play
Regular weekend	\$25.00 per play
Senior weekday (7:00 a.m. – 3:00 p.m.)	\$17.00 per play
Youth weekday & weekend	\$12.00 per play
Currie East and Currie West Municipal Golf Courses Membership Fees	
Season Membership privileges good April 1 through end of season	
Dual-Unlimited play (East-and West Courses)	
Single Season Membership	\$1000.00 per Membership
Couple season Membership	\$1500.00 per Membership
* Currie Dual Members receive:	
• 10% discount on all Golf Shop merchandise excluding special sale items	
• 10% discount on all Food Menu items	
Unlimited play - East Course Only	
Single season Membership	\$550.00 per Membership
Couple season Membership	\$750.00 per Membership
Youth season Membership	\$275.00 per Membership
* Currie East Members receive:	
• 20% discount on Currie West green fees	
• 10% discount on all Golf Shop merchandise excluding special sale items	
• 10% discount on all Food Menu items	
Unlimited play - West Course Only	
Single season Membership	\$ 750.00 per Membership
Couple season Membership	\$1200.00 per Membership
Youth season Membership	\$ 400.00 per Membership
* Currie West Members receive:	
• 20% discount on Currie East green fees	
• 10% discount on all Golf Shop merchandise excluding special sale items	
• 10% discount on all Food Menu items	
Senior restricted play - (West Course Only Monday through Friday before 3:00 p.m.)	
Single season Membership	\$600.00 per Membership
Couple season Membership	\$1100.00 per Membership
* Currie West Members receive:	
• 20% discount on Currie East green fees	
• 10% discount on all Golf Shop merchandise excluding special sale items	
• 10% discount on all Food Menu items	
Senior restricted play – (East Course Only Monday through Friday before 3:00 p.m.)	
Single season Membership	\$450.00 per Membership
Couple season Membership	\$700.00 per Membership
* Currie East Members receive:	
• 20% discount on Currie West green fees	
• 10% discount on all Golf Shop merchandise excluding special sale items	
• 10% discount on all Food Menu items	

UNAPPROVED

Family Membership (West Course Only for Unlimited Family Members 18 years of age and under) \$1450.00 per Membership

* Currie West Members receive:

- 20% discount on Currie East green fees
- 10% discount on all Golf Shop merchandise excluding special sale items
- 10% discount on all Food Menu items

Family Membership (East Course only for Unlimited Family Members 18 years of age and under) \$1100.00 per Membership

* Currie East Members receive:

- 20% discount on Currie West green fees
- 10% discount on all Golf Shop merchandise excluding special sale items
- 10% discount on all Food Menu items

Power Cart Fees

9 Holes per person

Not to exceed \$ 9.00

18 Holes per person

Not to exceed \$15.00

Cart Lease

Single

\$450.00 per season

Couple

\$675.00 per season

Trail Fee (Private carts used only by owner or member of immediate family.) All other riders must pay a cart rental fee.

Season pass

\$450.00 per pass

Daily pass

\$ 10.00 per pass

Par Three Course Daily Fees

Par 3 – Regular

\$6.50 per play

Par 3 – Senior

\$4.50 per play

Par 3 – Youth

\$2.50 per play

Driving Range Fees

Driving Range

Small Basket

\$3.00

Medium Basket

\$5.00

Large Basket

\$7.00

Driving Range Season Membership Fees

Single

\$200.00

Course Season Membership (Single)

\$125.00

Course Season Membership (Couple)

\$200.00

Youth Golf Program

Program Fee

\$70.00 or Youth Membership

Senior is defined as 60 years of age and older.

Youth is defined as 18 years of age and under.

Couple is defined as husband and wife.

Family is defined as husband and wife and their children 18 years of age and under.

Exception: The Golf Course Manager is authorized with the approval of the City Manager to reduce daily fees on a discretionary basis for the purpose of marketing additional play.

Section 2. This Ordinance shall take effect upon publication. (Ordinance ADOPTED. Yeas: Adams, Donker, Gaynor Nays: Johnson, Wazbinski)

UNAPPROVED

PETITIONS AND REQUESTS FOR CAPITAL IMPROVEMENT PROJECTS

City Engineer Brian McManus presented four petitions and requests for capital projects for consideration of inclusion in the 2010 Construction Program. The following four resolutions were then presented for consideration.

WATER MAIN ON WALDO AVENUE

Petitioner David Rapanos, 5903 Wildflower Circle, spoke in support of the water and sewer petitions on Waldo Avenue. The following resolution was then offered by Councilman Johnson and seconded by Councilman Wazbinski:

RESOLVED, that the attached petition received from David G. Rapanos for the installation of a water main on Waldo Avenue from Wheeler Street to Diamond Drive, is hereby received and referred to the City Engineering Department for consideration of inclusion in the 2010 Construction Program. (Motion ADOPTED.)

SANITARY SEWER ON WALDO AVENUE

The following resolution was offered by Councilman Wazbinski and seconded by Councilman Adams:

RESOLVED, that the attached petition received from David G. Rapanos for the installation of a water main on Waldo Avenue from Wheeler Street to Diamond Drive, is hereby received and referred to the City Engineering Department for consideration of inclusion in the 2010 Construction Program. (Motion ADOPTED.)

NON-MOTORIZED TRANSPORTATION IMPROVEMENTS

David Waite, Chair of the Non-Motorized Transportation Committee, spoke in support of the Non-Motorized Transportation Improvement request. The following resolution was then offered by Councilman Adams and seconded by Councilman Gaynor:

RESOLVED, that the attached petition received from the Non-Motorized Transportation Advisory Committee for the installation of various non-motorized transportation improvements on existing city streets, is hereby received and referred to the City Engineering Department for consideration of inclusion in the 2009 Construction Program. (Motion ADOPTED.)

PEDESTRIAN BRIDGE ACROSS SAGINAW ROAD

Royal Braley, Jr. 2200 Wisconsin Street, Colleen Dolan, Cherryview Drive, Linda Graff, 209 Wanetah, and Steve Dolan, 1211 Timber, all spoke in favor of the pedestrian bridge across Saginaw Road. David Waite, Non-Motorized Transportation Committee Chair, spoke in support of doing something to enhance the safety for non-motorized activities at this intersection. The following resolution was then offered by Councilman Johnson and seconded by Councilman Adams:

RESOLVED, that the attached petition received from Royal E. Braley, Jr. for the installation of a pedestrian bridge across Saginaw Road at Eastlawn Drive, is hereby received and referred to the City Engineering Department for consideration of inclusion in the 2009 Construction Program. (Motion DENIED. Yeas: None Nays: Adams, Donker, Gaynor, Johnson, Wazbinski)

Council recessed at 10:05 p.m. and reconvened at 10:15 p.m.

CITY FOREST SUBDIVISION NO. 1 & 2 SIDEWALK TIME EXTENSION

Director of Planning and Community Development Keith Baker presented information on a request received for a two-year extension of time for completion of sidewalk in City Forest

UNAPPROVED

Estates Subdivision No. 1 and No. 2. The following two resolutions were then presented for consideration.

SIDEWALK TIME EXTENSION – CITY FOREST ESTATES SUBDIVISION NO. 1

The following resolution was offered by Councilman Adams and seconded by Councilman Wazbinski:

WHEREAS, a written request has been received from Roy Wise of Wiskin Developments, Inc., proprietor of City Forest Estates Subdivision No. 1, to extend the period of time to complete the sidewalk within said subdivision; now therefore

RESOLVED, that in accord with the Code of Ordinances of the City of Midland, the City Council hereby extends the period of time to complete the sidewalk within City Forest Estates Subdivision No. 1 until January 10, 2012 conditioned upon receipt of a financial guarantee in an amount determined by the City Engineer, valid for a period of one year beyond the date of the required completion of the sidewalk; and

RESOLVED FURTHER, that if a new financial guarantee is not provided by January 15, 2010, Council authorizes staff to use the existing financial guarantee on file to install all remaining sidewalk. (Motion ADOPTED.)

SIDEWALK TIME EXTENSION – CITY FOREST ESTATES SUBDIVISION NO. 2

The following resolution was offered by Councilman Wazbinski and seconded by Councilman Johnson:

WHEREAS, a written request has been received from Roy Wise of Wiskin Developments, Inc., proprietor of City Forest Estates Subdivision No. 2, to extend the period of time to complete the sidewalk within said subdivision; now therefore

RESOLVED, that in accord with the Code of Ordinances of the City of Midland, the City Council hereby extends the period of time to complete the sidewalk within City Forest Estates Subdivision No. 2 until April 14, 2012 conditioned upon receipt of a financial guarantee in an amount determined by the City Engineer, valid for a period of one year beyond the date of the required completion of the sidewalk; and

RESOLVED FURTHER, that if a new financial guarantee is not provided by January 15, 2010, Council authorizes staff to use the existing financial guarantee on file to install all remaining sidewalk. (Motion ADOPTED.)

2009 CONSTRUCTION PROJECT REPORT

The following resolution was offered by Councilman Gaynor and seconded by Councilman Adams:

WHEREAS, the City Engineer reported the status of completion for projects in the 2009 Construction Program; now therefore

RESOLVED, that City Council hereby receives and files the 2009 Construction Progress Report. (Motion ADOPTED.)

LOCC DETERMINATIONS

City Clerk Selina Tisdale presented the filing of the 2009 Local Officers' Compensation Commission Determinations and a resolution placing the 2009 LOCC Determinations on the December 21, 2009 City Council agenda for the purpose of hearing public comments. The following resolution was then offered by Councilman Johnson and seconded by Councilman Adams:

UNAPPROVED

WHEREAS, in accord with Article IX of Chapter 2 of the Code of Ordinances, the Local Officers' Compensation Commission has duly met and approved its 2009 Local Officers' Compensation Commission Determinations; and

WHEREAS, said determinations were officially filed by the Chairman of the Local Officers' Compensation Commission in the Office of the City Clerk, 333 W. Ellsworth Street, Midland, Michigan on November 23, 2009; and

WHEREAS, in accord with Article IX of Chapter 2 of the Code of Ordinances the determinations made by the Local Officers' Compensation Commission shall become effective on December 23, 2009 unless said determinations are rejected by a 4/5 vote of the City Council; now therefore

RESOLVED, that the City Clerk's notification of the filing of 2009 Determinations of the Local Officers' Compensation Commission of the City of Midland on November 23, 2009 is hereby acknowledged by the City Council as having been received; and

RESOLVED FURTHER, that the City Council hereby directs that an additional copy of the 2009 Determinations of the Local Officers' Compensation Commission be filed in the Governmental Corner of the Grace A. Dow Memorial Library for public review; and

RESOLVED FURTHER, that the City Manager is hereby directed to place this item on the December 21, 2009 City Council agenda for the purpose of hearing any public comments prior to any action taken by the City Council. (Motion ADOPTED.)

101 E. MAIN LIQUOR LICENSE (Step 1)

The following resolution was offered by Councilman Gaynor and seconded by Councilman Adams:

RESOLVED, that the request to: TRANSFER OWNERSHIP OF 2009 CLASS C LICENSED BUSINESS WITH DANCE-ENTERTAINMENT PERMIT, LOCATED AT 101 E. MAIN, MIDLAND, MI 48640, MIDLAND COUNTY FROM GRANT HAMILTON GROUP LLC TO AUSTIN JAMES LLC WITH LICENSE TO BE HELD IN ESCROW be considered for approval. It is the consensus of this legislative body that the application be: Recommended for issuance. (Motion ADOPTED.)

101 E. MAIN LIQUOR LICENSE (Step 2)

The following resolution was offered by Councilman Gaynor and seconded by Councilman Adams:

RESOLVED, that the request to: TRANSFER OWNERSHIP OF 2009 CLASS C LICENSED BUSINESS WITH DANCE-ENTERTAINMENT PERMIT, LOCATED IN ESCROW AT 101 E. MAIN, MIDLAND, MI 48640, MIDLAND COUNTY FROM AUSTIN JAMES LLC TO SCHAFER HILL VENTURES LLC (Step 2) WITH EXISTING OUTDOOR SERVICE AREA WHICH IS LOCATED ON THE CITY OF MIDLAND'S SIDEWALK be considered for approval. It is the consensus of this legislative body that the application be: Recommended for issuance. (Motion ADOPTED.)

MIDMICHIGAN MEDICAL CENTER-MIDLAND VOLUNTEERS – CHARITABLE GAMING LIC.

The following resolution was offered by Councilman Gaynor and seconded by Councilman Adams:

RESOLVED, that the request from MidMichigan Medical Center-Midland Volunteers of Midland, county of Midland, asking that they be recognized as a nonprofit organization operating in the community for the purpose of obtaining a charitable gaming license, be considered for approval. (Motion ADOPTED.)

UNAPPROVED

LEGAL SERVICES FOR EASTLAWN ARMS TAX APPEAL

The following resolution was offered by Councilman Gaynor and seconded by Councilman Adams:

WHEREAS, the Gordon Management Company appealed the 2004 – 2009 assessments and taxable values of real property it owns in the City of Midland to the Michigan Tax Tribunal; and
WHEREAS, the law firm of Braun, Kendrick, Finkbeiner, P.L.C. has been retained in assisting the City of Midland in its legal defense of said appeal; and
WHEREAS, the cost of said services is expected to exceed \$20,000 and therefore approval of the City Council is required under Section 2-18 of the Code of Ordinances; and
WHEREAS, sufficient budgetary funding exists within the 2009-2010 Legal Fees budget for general tax appeal cases; now therefore
RESOLVED, that the above-referenced services are hereby determined to be professional services within the meaning of Section 2-19 of the Code of Ordinances and do not require sealed proposals; and
RESOLVED FURTHER, that authorization for payment to the legal firm of Braun, Kendrick, Finkbeiner, P.L.C. for their assistance in connection with the aforementioned appeal is hereby authorized in an amount not to exceed \$34,000. (Motion ADOPTED.)

ZONING TEXT AMENDMENT NO. 149A

The following resolution was offered by Councilman Gaynor and seconded by Councilman Adams:

RESOLVED, that notice is hereby given that a public hearing will be held by the City Council on Monday, January 11, 2010, at 7:00 p.m. in the Council Chambers, City Hall, for the purpose of considering the advisability of amending the Zoning Map of Ordinance No. 1585, the Zoning Ordinance of the City of Midland, as set forth in the following proposed Ordinance, which is hereby introduced and given first reading; and
RESOLVED FURTHER, that the City Clerk is hereby directed to publish said notice on December 19, 2009.

ORDINANCE NO. _____

AN ORDINANCE TO AMEND ORDINANCE NO. 1585, BEING AN ORDINANCE TO REGULATE AND RESTRICT THE LOCATION OF TRADES AND INDUSTRIES AND THE LOCATION OF BUILDINGS DESIGNED FOR SPECIFIC USES, TO REGULATE AND LIMIT THE HEIGHT AND BULK OF BUILDINGS HEREAFTER ERECTED OR ALTERED, TO REGULATE AND DETERMINE THE AREA OF YARDS, COURTS, AND OTHER OPEN SPACES SURROUNDING BUILDINGS, TO REGULATE AND LIMIT THE DENSITY OF POPULATION, AND FOR SAID PURPOSES, TO DIVIDE THE CITY INTO DISTRICTS AND PRESCRIBE PENALTIES FOR THE VIOLATION OF ITS PROVISIONS BY AMENDING THE ZONING ORDINANCE TO FURTHER DEFINE PERMITTING AND FOUNDATION REQUIREMENTS FOR ACCESSORY STRUCTURES IN THE CITY OF MIDLAND.

The City of Midland Ordains:

Section 1. That the Zoning Map of Ordinance No. 1585, being the Zoning Ordinance of the City of Midland, is hereby amended as follows:

Section 2.02 – DEFINITIONS

RAT WALL: A low perimeter foundation wall that is both below and above grade, intended to prevent rodents and burrowing animals from accessing the sub-floor area.

UNAPPROVED

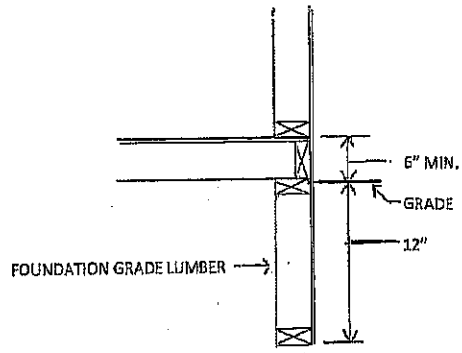
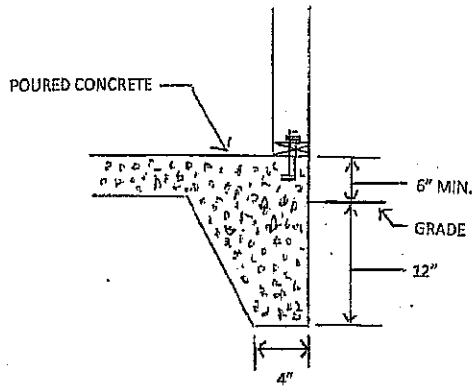

UNAPPROVED

Section 3.03 -- ACCESSORY BUILDINGS AND STRUCTURES

A. General Requirements

5. Applicability of Other Codes and Ordinances

Accessory buildings and structures shall be subject to all other applicable codes and ordinances regarding construction, installation, and operation. A zoning compliance permit, as outlined in Section 31.06, shall be required for all accessory buildings and structures with floor area between 50 and 200 square feet. Any accessory structure greater than 200 square feet in floor area shall require a building permit.

6. Foundations

All Accessory buildings and structures with a floor area between 50 and 200 square feet shall be required to have a rat wall foundation that extends a minimum of 12" below surrounding grade. The rat wall foundation shall be constructed from concrete, block or foundation grade lumber and conforms to the Michigan Building Code. An accessory building may also be placed on a concrete slab which extends a minimum of 2 feet horizontally from all four sides of the structure.

Section 31.06 ZONING COMPLIANCE PERMIT

B. Zoning Compliance Permit

1. Permit Required

- a. A zoning compliance permit shall be required prior to any construction on vacant or improved land, or any construction or alterations whether requiring a building permit or not. Zoning compliance permits shall be issued concurrently with building permits.
- b. In addition, any change of land use shall also require a zoning compliance permit to ensure that all applicable zoning ordinance requirements are adhered to and compliance with the Zoning Ordinance is achieved.

2. Application Requirements

No permit shall be issued for construction, alteration, or remodeling of any building or structure where a change in land use is proposed until an application has been submitted, showing that the proposed uses, structures and buildings are in conformance with the provisions of this Ordinance.

Applications for permits required by this Section shall be filed with the Building Official.

Section 2. All Ordinances or parts of Ordinances in conflict herewith are hereby repealed only to the extent necessary to give this Ordinance full force and effect.

Section 3. This Ordinance shall take effect upon publication. (Motion ADOPTED. Considered first reading.)

Being no further business the meeting adjourned at 10:35 p.m.

Selina Tisdale, City Clerk