

GENERAL NOTES:

8" HDPE – LFG PIPELINE BORINGS UNDER HIGHWAY US-10 AND ASHMAN STREET:

The LFG pipeline casing boring shall consist of furnishing and placing approximately 190 lineal feet of 14" steel casing pipe with a minimum wall thickness of 0.250 inches by the boring method. The boring shall be completed in accordance with M.D.O.T. "Provisions for Bore and Jack Construction in Connection with Permit Operations". The annular space between the LFG pipeline and casing shall be filled with pea stone. Both ends of the casing shall be bulkheaded with 12" of commercial grade concrete. The price bid per lineal foot of LFG pipeline shall include all equipment and materials required to install the pipe in the center of the casing pipe. The method of placement of the LFG pipeline within the casing pipe shall be approved by the Engineer prior to installation.

8" HDPE – LFG PIPELINE TRACER WIRE:

A single tracer wire shall be laid along with the main for location purposes. The wire shall be brought up through and securely fastened at the finished ground elevation inside each structure, including condensate drain manholes. The tracer wire shall be designed and manufactured for the purpose of detecting buried utilities. Tracer wire shall be 12 AWG (minimum) solid copper wire coated with a 30 mil (minimum) polyethylene jacket. The Contractor shall use larger wire when necessary for installation without damage during bored installations. The wire shall be attached in such a manner that it will not become displaced during construction and backfilling. Tracer wire shall be continuous (without any splices) over each run. Location wire test stations shall be placed at intervals not to exceed 1000 feet. If the wire is damaged or broken during installation, a new wire shall be installed by the Contractor. The Contractor shall demonstrate continuity of the installed tracer wire to the Engineer prior to acceptance.

8" HDPE – DIRECTIONAL BORES OF CITY STREETS:

The 8" HDPE LFG crossings of City streets shall be installed by directional drilling. This will minimize impacts on traffic and restoration of the street surfaces. The Contractor shall contact the City of Midland and private utility companies to arrange for the exact location of the bore to protect existing public utilities under the street.

RESTORATION:

All landscaping and outlaws shall be restored to a condition equal to or better than prior to construction. Any areas disturbed by the Contractor's operations shall be backfilled, covered with 4" of screened topsoil, neatly graded and hydroseeded. The cost for all restoration shall be included with the unit price bid per foot of pipe.

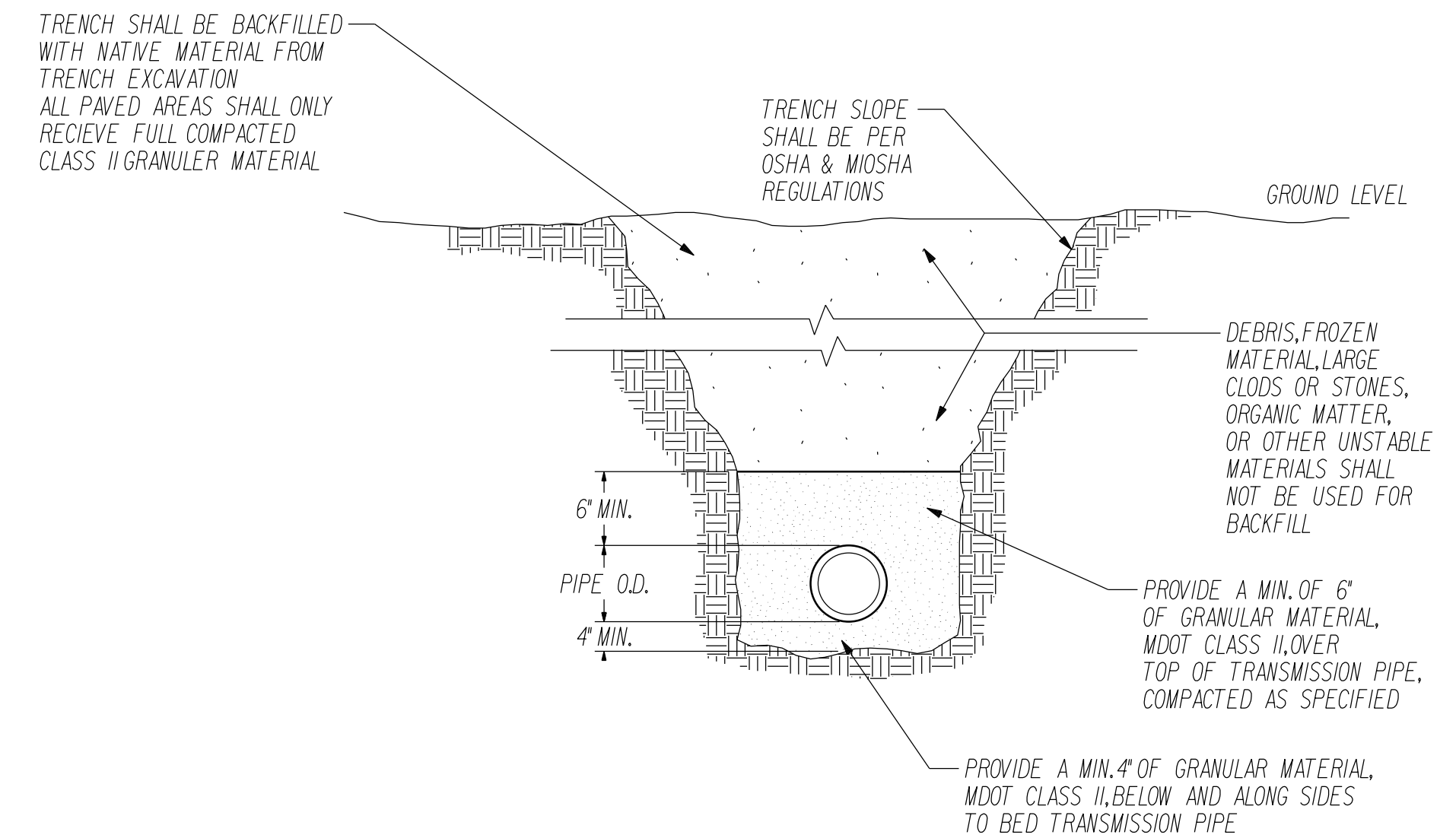

STANDARD TRENCH DETAIL

NOT TO SCALE

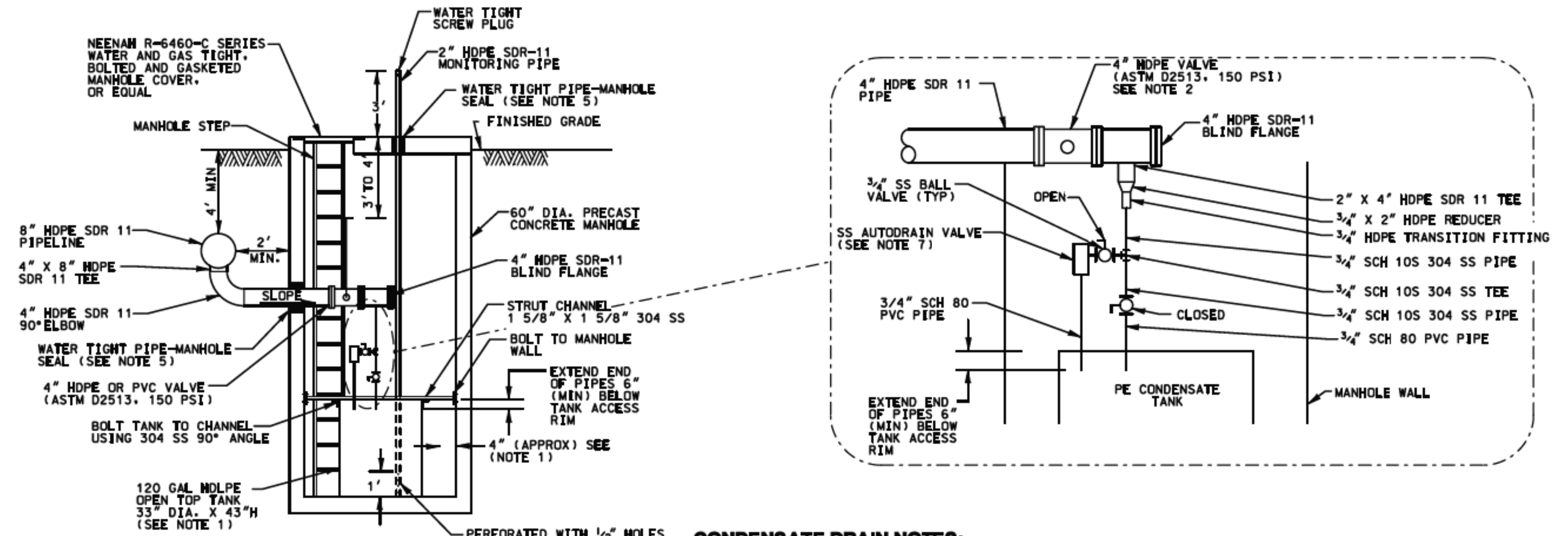

CONDENSATE DRAIN NOTES:

1. INSTALL 120 GALLON POLYETHYLENE (HDPE OR HDXPE) OPEN TOP TANK AS SHOWN. POSITION TANK IN MANHOLE SUCH THAT TANK ACCESS WAY IS BELOW MANHOLE COVER, AND THERE IS APPROXIMATELY 8 INCH BETWEEN INSIDE MANHOLE WALL AND OUTSIDE TANK WALL AT TANK ACCESS. PE TANK SHALL BE SNYDER INDUSTRIES, INC. (#570001) OR EQUAL.
2. 4" HDPE OR PVC VALVE SHALL BE MANUFACTURED IN THE USA ACCORDANCE WITH ASTM D2513. HANDLE SHALL BE EXTENDED USING SINGLE STEM EXTENSION TO 3 OR 4 FEET BELOW MANHOLE COVER. THE VALVE SHALL BE CLOSED UNDER NORMAL CONDITIONS. THE VALVE WILL OPENED TEMPORALLY DURING DEWATERING OF THE PIPELINE.
3. ALL HDPE PIPE SHALL BE MANUFACTURED IN THE USA BY PERFORMANCE PIPE (OR EQUAL) USING PE 4710, PE 3608 OR PE 3408 RESIN AND ASTM D 2513. PIPE SHALL BE MARKED IN ACCORDANCE WITH ASTM D 2513.
4. FLANGES AND FLANGE ACCESSORIES MUST MEET THE MINIMUM REQUIREMENTS OF ASME/ANSI B16.5. MSS SP-44 OR THE EQUIVALENT.
5. WATER TIGHT PIPE TO MANHOLE SEAL SHALL BE LINK-SEAL, A-LOK, Z-LOK, OR QUIK-LOK, OR EQUAL.
6. 3/4 INCH SS BALL VALVES SHALL BE APOLLO SERIES 96-100, OR EQUAL.
7. AUTOMATIC DRAIN VALVE SHALL BE ARMSTRONG MODEL 22-LD, STAINLESS STEEL, FREE FLOATING GUIDED LEVER DRAIN TRAP, OR EQUAL.

CONDENSATE DRAIN MANHOLE DETAIL

NOT TO SCALE

DATE	REVISIONS	DATE	REVISIONS	DATE	REVISIONS

CITY OF MIDLAND, MICHIGAN
ENGINEERING DEPARTMENT
ROUTE PLAN
LANDFILL GAS TO ENERGY
WASTEWATER PLANT TO LANDFILL
SHEET 2 OF 7 SHEETS 2010 PROJECT 1

CITY OF MIDLAND, MICHIGAN APPROVAL FOR CONSTRUCTION	CITY OF MIDLAND, MICHIGAN APPROVAL FOR CONSTRUCTION
CITY ENGINEER	SOIL EROSION AND SEDIMENTATION CONTROL ADMINISTRATOR
DATE	DATE